

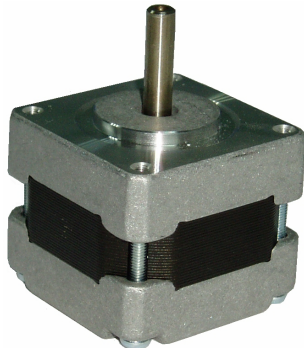

39HS Series Hybrid Stepping Motors



General Specifications

Step Angle Accuracy	±5%(full step, no load)
Temperature Rise	80°CMax
Ambient Temperature	-10°C —— +50°C
Insulation Resistance	100MΩmin.500VDC
Dielectric Strength	500VAC for one minute
Shaft Radial Play	0.06 Max.(450g-load)
Shaft Axial Play	0.08 max.(450g-load)

Electrical Specifications

Model Number	Step Angle Degree (°)	Motor Length L inch (mm)	Holding Torque Oz-in (Nm)	Number of Leads	Phase Current (Amps)	Phase Resistance (Ohm)	Phase Inductance (mH)	Rotor Inertia Oz-in-sec ² (g.cm ²)	Detent Torque Oz-in (g.cm)	Weight Oz (kg)
39HS02	1.8	1.34 (34)	31.15 (0.22)	4	0.6	15±10%	16±20%	0.000284 (20)	1.71 (122.4)	7.05 (0.20)

* Above motor is our typical model, and if you need a customization motor, please contact us.

Mechanical Specifications (Unit=mm, 1 inch=25.4mm)

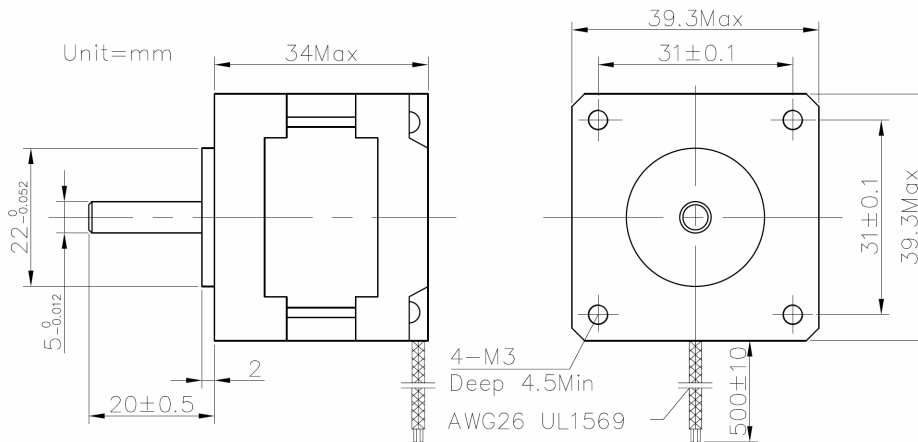

Figure 1: Mechanical specification of 39HS02

Wiring Diagram

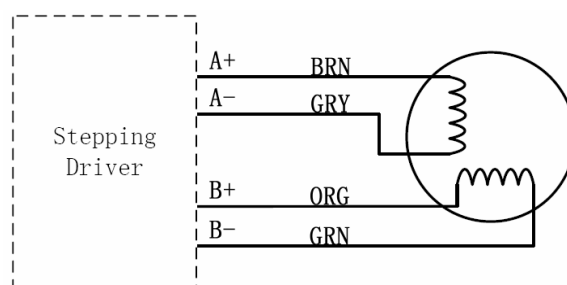

Figure 2: Wiring diagram